

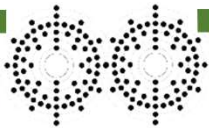

**fang** **T**  **TH**

# Precision Rolled Ball Screws 'R' Series [F2R] and 'Ø' Series [O2TH] zeroTOOTH motor Mount Technical Information

**Metric Leads &  
Diameters**



# Other Products



Linear Actuators | Ball Screws | Gearboxes | Lifts | Systems



## fangOPEN & fangMAX Precision Gear Rack Guided Actuators

And

## FINGLIDE Guided Ball Screw Actuators



## Servo & Industrial Gearboxes

Fangtooth will tackle any solution by making a custom to fit your exact requirement



CALL TODAY

## Multi-Axis Systems

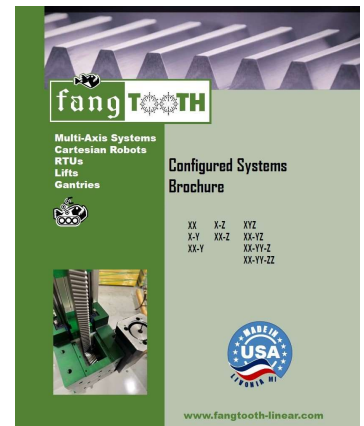

# BALLSCREW CATALOG CONTENTS

## “R” Series Rolled Screw

Page 4



High Quality Ball Screws with  
Internal re-circulation  
Order the whole assembly with one  
part number including the support  
bearings.



## “0” Series Motor Mount

Page 14



Simple to Drop into Design  
Longer Screws at Higher Speeds  
Increased Ball Screw L10 Life  
Perfect Motor Mount

Slip means Float for Float Adapter



INSPIRE . GREAT . AUTOMATION

www.fang2th.com - 11970 Mayfield - Livonia, MI 48150

# Product Offering

**F2RFU –**  
Rolled Flange Unit

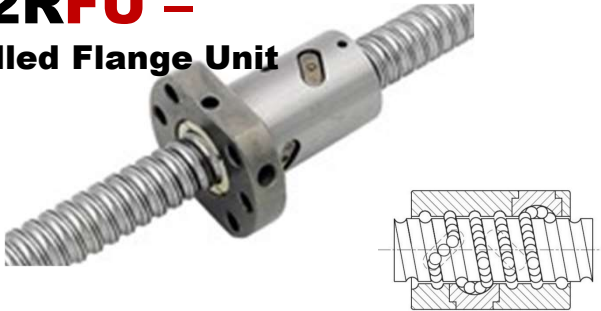

**F2RSQ –**  
Rolled Square Lead Plus High Speed



**F2RDF –**  
Rolled Double (nut) Flange

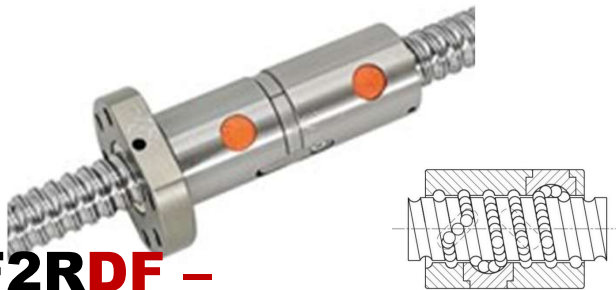

**F2RTY –**  
Rolled Toy Miniature



**BK-FIXED**



**BF-FREE**



**FK-FIXED**



**FF-FLOAT**



## Zero Tooth – Free/Fixed Zero Problem Motor Mounting

See ZeroTOOTH Catalog – Perfect Motor Alignment

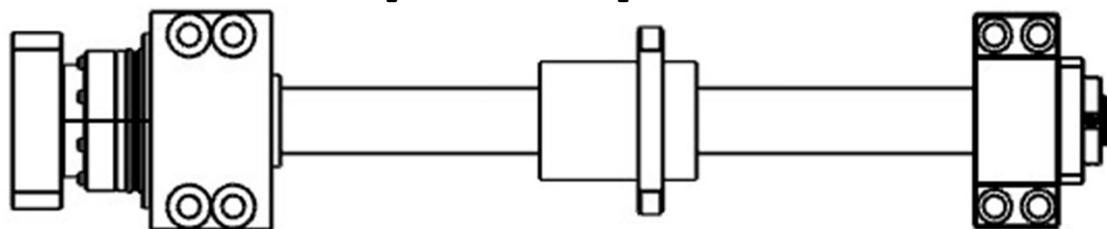

# Ball Nut Design & Lead Accuracy

## Ball Nut Type: F / D

The type F and D ball nut utilize internal ball returns of cast steel. The ball returns are captured in the ball nut to prevent the returns from coming out of the assembly during ball recirculation. This design allows for high DN (rotation speed) as well as high translational speeds when compared to external or end type ball returns.

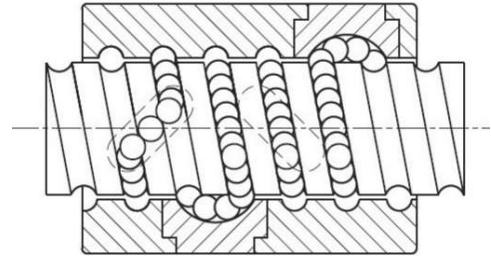

## Ball Nut Type: E

The type E ball screw is a high lead ball screw with end style ball returns. The high lead ball screws allow for high translation rates while maintaining lower critical speeds.

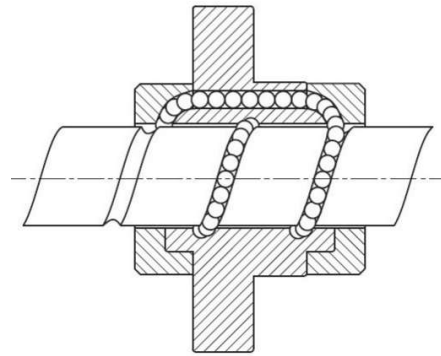

## Lead Accuracy

- The ball screws offered by Alpha have an accumulated travel deviations of grade C7 and C10. The value allowable per 300mm measured at any portion of the thread is 0.05mm for C7 and 0.21mm for C10.

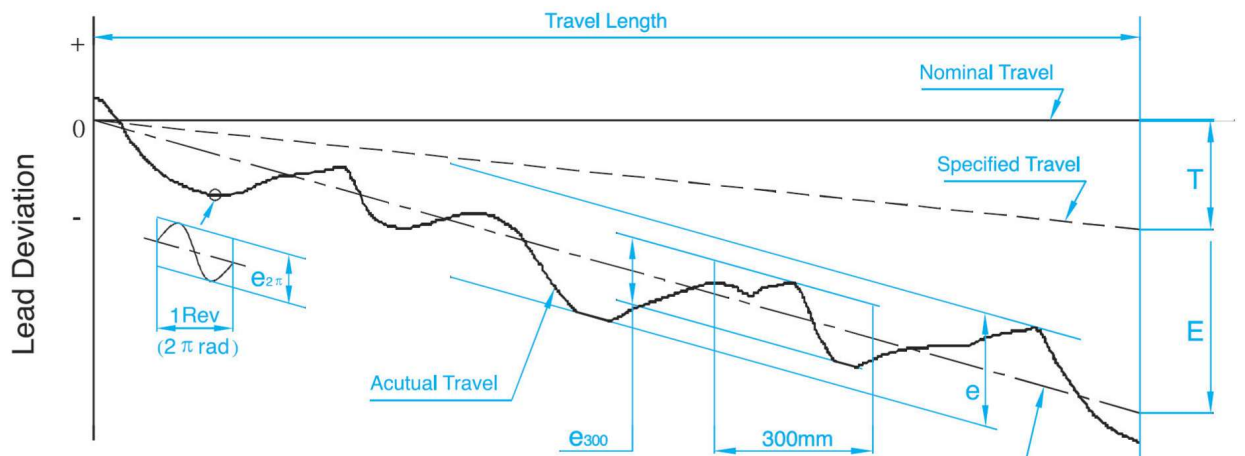

# Model Number Code: F2R Fangtooth 'R' Rolled

**F2RFU - 16 05 - 0400 - BK12 / BF12**    ASM: Support Bearings Included  
 MIN: Minus Support Bearings

Base Model	
FU	Flange Unit
DF	Double Flange
SQ	Square Lead
TY	Toy Miniature

Screw Diameter	
4	Size: 4 mm
6	Size: 6 mm
8	Size: 8 mm
10	Size: 10 mm
12	Size: 12 mm
14	Size: 14 mm
16	Size: 16 mm
20	Size: 20 mm
25	Size: 25 mm
32	Size: 32 mm
40	Size: 40 mm
50	Size: 50 mm
63	Size: 63 mm
80	Size: 80 mm
100	Size: 100 mm

Lead	
1	1 mm
2	2mm
2.5	2.5 mm
3	3 mm
5	5 mm
10	10 mm
16	16 mm
20	20 mm
25	25 mm
32	32 mm
40	40 mm
50	50 mm
64	63 mm

Overall Length
100 – 6000 mm

End Machining	
BK10	BF10
BK12	BF12
BK15	BF15
BK17	BF17
BK20	BF20
BK25	BF25
BK30	BF30
BK35	BF35
BK40	BF40

• Left-hand thread available for some combinations of screw size, lead, and nut type.

- Type FK or FF machining available as well.
- May also include two fixed mounted bearings.
- Unsupported ends XX also available.
- Custom ends must be defined on drawing.

### IMPORTANT NOTES

BKBF – Flange Faces Drive End  
 BFBK – Flange Faces Float End  
 FKFF – Flange Faces Drive End  
 FFFK – Flange Faces Float End

### Shaft End Machining

**Bearing Block – Fixed Mount**

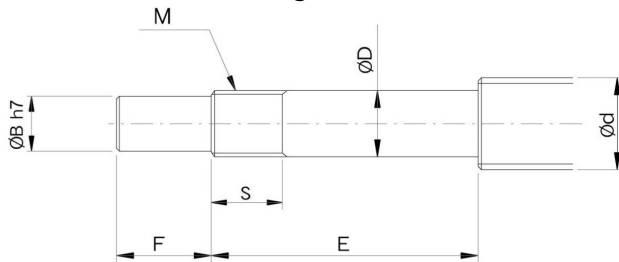

Unit : mm

**Bearing Block – Float Mount**

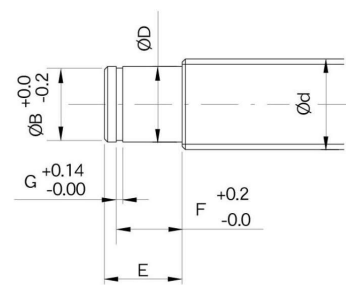

Support Unit	Ball Screw Diameter Ød	Drive Shaft Diameter ØB	Bearing Shaft Diameter ØD	Bearing Shaft Length E	Drive Shaft Length F	Lock Nut Thread M	Thread Length S
BK12	16	10	12	36	15	M12 x 1	14
BK15	20	12	15	40	20	M15 x 1	12
BK20	25	17	20	53	25	M20 x 1	15
BK25	32	20	25	65	30	M25 x 1.5	18
BK30	40	25	30	72	38	M30 x 1.5	25
BK40	50	35	40	93	50	M40 x 1.5	35

Support Unit	Ball Screw Diameter Ød	Snap Ring Diameter ØB	Shaft Diameter ØD	Shaft Length E	Bearing & C-Ring Length F	C-Ring Width G
BF12	16	9.6	10	11	9.15	1.15
BF15	20	14.3	15	13	10.15	1.15
BF20	25	19	20	19	15.35	1.35
BF25	32	23.9	25	20	16.35	1.35
BF30	40	28.6	30	21	17.75	1.75
BF40	50	38	40	23	19.75	1.75

# F2RFU Ball Screw

## Fangtooth Rolled Flange Unit

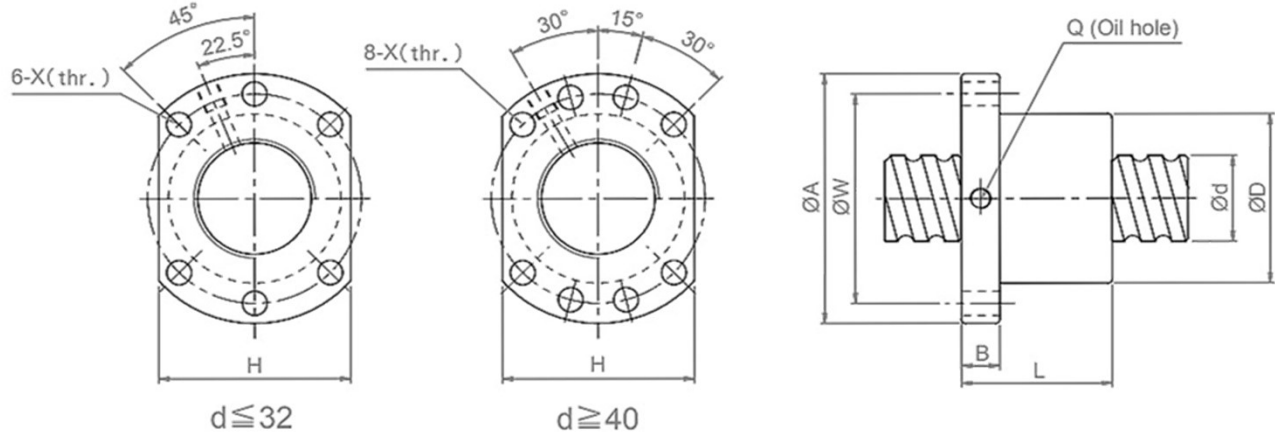

Units: mm

Basic Model	Ball Circle Dia		(D)	(A)	(B)	(L)	(W)	(X)	(H)	(Q)	$(C_{dyn})$	$(C_0)$
	(d)	Lead										
F2RFU1605-4	16 mm	5 mm	28	48	10	50	38	5.5	40	M6	1720 lbs	3946 lbs
F2RFU1610-3	16 mm	10 mm	28	48	10	47	38	5.5	40	M6	1590 lbs	2754 lbs
F2RFU2005-4	20 mm	5 mm	36	58	10	51	47	6.6	44	M6	2492 lbs	5248 lbs
F2RFU2010-3	20 mm	10 mm	36	58	10	57	47	6.6	40	M6	1841 lbs	3704 lbs
F2RFU2505-4	25 mm	5 mm	40	62	10	51	51	6.6	48	M6	2822 lbs	6858 lbs
F2RFU2510-4	25 mm	10 mm	40	62	10	85	51	9.0	48	M6	4287 lbs	8549 lbs
F2RFU3205-4	32 mm	5 mm	50	80	12	52	65	9.0	62	M6	3197 lbs	9151 lbs
F2RFU3210-4	32 mm	10 mm	50	80	12	85	65	9.0	62	M8	7475 lbs	15810 lbs
F2RFU4005-4	40 mm	5 mm	63	93	12	55	78	9.0	70	M8	3550 lbs	11753 lbs
F2RFU4010-4	40 mm	10 mm	63	93	14	93	78	9.0	70	M8	8622 lbs	20992 lbs
F2RFU5005-4	50 mm	5 mm	75	110	14	55	93	11.0	85	M8	3815 lbs	14912 lbs
F2RFU5010-4	50 mm	10 mm	75	110	15	93	93	11.0	85	M8	9812 lbs	27563 lbs
F2RFU5020-4	50 mm	20 mm	75	110	16	138	93	11.0	85	M8	10240 lbs	31591 lbs
F2RFU6310-4	63 mm	10 mm	90	125	18	98	108	11.0	95	M8	11179 lbs	35280 lbs
F2RFU6320-4	63 mm	20 mm	95	135	20	149	115	13.5	100	M8	16698 lbs	52589 lbs
F2RFU8010-4	80 mm	10 mm	105	145	20	98	125	13.5	110	M8	12392 lbs	46967 lbs
F2RFU8020-4	80 mm	20 mm	125	165	25	154	145	13.5	130	M8	18709 lbs	68123 lbs
F2RFU10020-4	100 mm	20 mm	150	202	30	180	170	17.5	155	M8	20771 lbs	86399 lbs



# F2RDF Ball Screw

## Fangtooth Rolled Double (nut) Flange

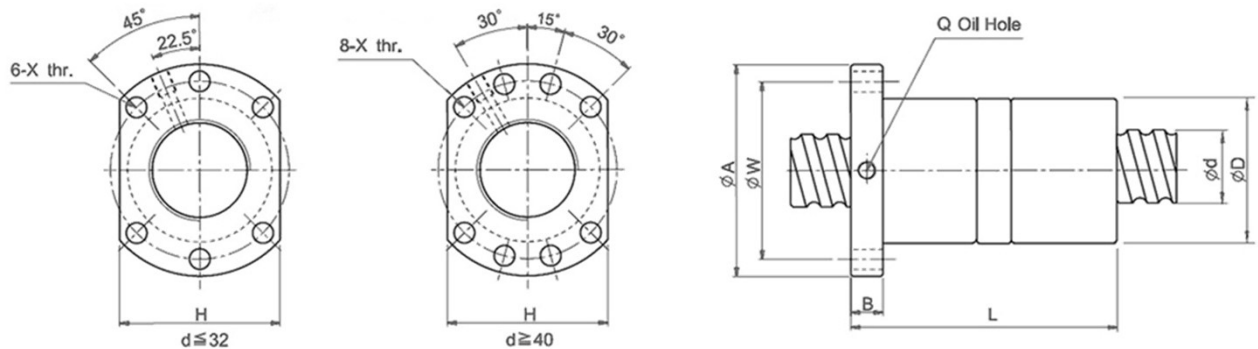

Units: mm

Basic Model	Ball Circle Dia		(D)	(A)	(B)	(L)	(W)	(X)	(H)	(Q)	$(C_{dyn})$	$(C_0)$
	(d)	Lead										
F2RDF1605-4	16 mm	5 mm	28	48	10	100	38	5.5	40	M6	1720 lbs	2754 lbs
F2RDF2005-4	20 mm	5 mm	36	58	10	101	47	6.6	44	M6	2492 lbs	5248 lbs
F2RDF2505-4	25 mm	5 mm	40	62	10	101	51	6.6	48	M6	2822 lbs	6858 lbs
F2RDF3205-4	32 mm	5 mm	50	80	12	102	65	9.0	48	M6	3197 lbs	9151 lbs
F2RDF3210-4	32 mm	10 mm	50	80	12	162	65	9.0	62	M8	7475 lbs	15810 lbs
F2RDF4005-4	40 mm	5 mm	63	93	14	105	78	9.0	62	M8	3550 lbs	11753 lbs
F2RDF4010-4	40 mm	10 mm	63	93	14	165	78	9.0	70	M8	8622 lbs	20992 lbs
F2RDF5010-4	50 mm	10 mm	75	110	16	171	93	11.0	70	M8	9812 lbs	27563 lbs
F2RDF6310-4	63 mm	10 mm	90	125	18	182	108	11.0	95	M8	11179 lbs	35280 lbs
F2RDF8010-4	80 mm	10 mm	105	145	20	182	125	13.5	110	M8	12392 lbs	46967 lbs
F2RDF8020-4	80 mm	20 mm	125	165	25	295	145	13.5	130	M8	20771 lbs	68123 lbs





# F2RSQ Ball Screw

## Fangtooth Rolled Square Lead Plus (High Speed)

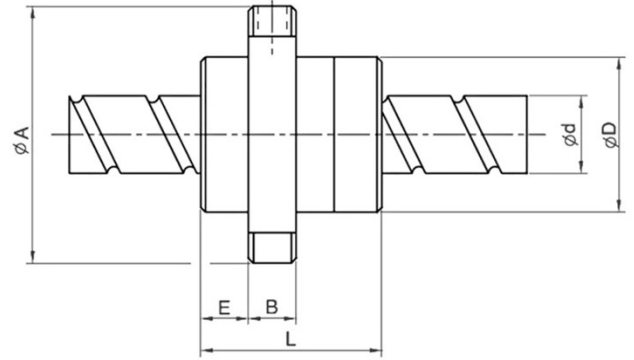
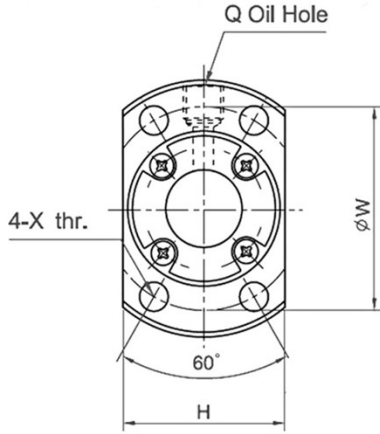

Units: mm

Basic Model	Ball Circle Dia		(D)	(A)	(E)	(B)	(L)	(W)	(X)	(H)	(Q)	$C_{dyn}$	$C_0$
	(d)	Lead											
F2RSQ1616-6	16 mm	16 mm	32	53	10.1	10	38	42	4.5	34	M6	2601 lbs	5622 lbs
F2RSQ1632-3	16 mm	32 mm	24	53	10.5	10	34	45	5.5	36	M6	1808 lbs	2998 lbs
F2RSQ2020-6	20 mm	20 mm	39	62	11.5	10	55	50	5.5	41	M6	3924 lbs	9436 lbs
F2RSQ2040-3	20 mm	40 mm	39	58	11	10	41	48	5.5	40	M6	2006 lbs	3880 lbs
F2RSQ2525-6	25 mm	25 mm	47	74	13	12	57	60	6.6	49	M6	5864 lbs	14749 lbs
F2RSQ2550-3	25 mm	50 mm	47	70	13	12	50	58	6.6	48	M6	3020 lbs	6085 lbs
F2RSQ3232-6	32 mm	32 mm	58	92	16	12	82	74	9.0	60	M6	8576 lbs	23148 lbs
F2RSQ3264-3	32 mm	64 mm	58	92	15.5	12	62	74	9.0	60	M6	4409 lbs	9392 lbs
F2RSQ4040-6	40 mm	40 mm	73	114	19	19	100	93	11.0	75	M6	13669 lbs	38801 lbs
F2RSQ5050-6	50 mm	50 mm	90	135	21.5	20	125	112	11.0	92	M6	16005 lbs	60847 lbs



# F2RTY Ball Screw Toy Miniature

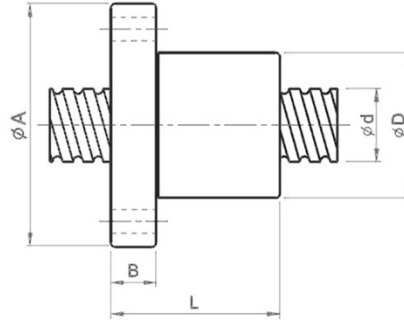
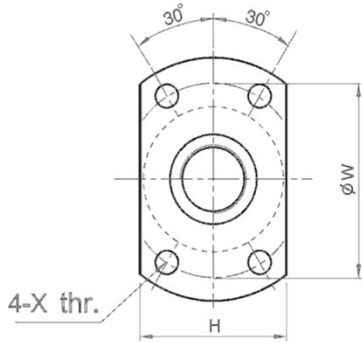

Units: mm

Basic Model	Ball Circle Dia										$(C_{dyn})$	$(C_0)$
	$(d)$	Lead	$(D)$	$(A)$	$(B)$	$(L)$	$(W)$	$(X)$	$(H)$	$(Q)$		
F2RTY0401-2	4 mm	1 mm	10	20	10	12	15	2.9	34	-	141 lbs	214 lbs
F2RTY0601-3	6 mm	1 mm	12	24	10	15	18	3.4	36	-	245 lbs	494 lbs
F2RTY0801-4	8 mm	1 mm	14	27	10	16	21	3.4	41	-	355 lbs	888 lbs
F2RTY0802-3	8 mm	2 mm	14	27	10	16	21	3.4	40	-	489 lbs	1010 lbs
F2RTY082.5-3	8 mm	2.5 mm	16	29	10	26	23	3.4	49	-	487 lbs	1008 lbs
F2RTY1002-3	10mm	2 mm	18	35	12	28	27	4.5	48	M6	536 lbs	1254 lbs
F2RTY1004-3	10 mm	4 mm	26	46	12	34	36	4.5	60	-	1032 lbs	1995 lbs
F2RTY1202-4	12 mm	2 mm	20	37	12	28	29	4.5	60	-	736 lbs	1997 lbs
F2RTY1402-4	14 mm	2 mm	21	40	14	23	31	5.5	75	-	780 lbs	2321 lbs
F2RTY1602-4	16 mm	2 mm	25	43	14	40	35	5.5	92	-	822 lbs	2646 lbs



# Fangtooth Ball Screw Mounting Screw and Nut

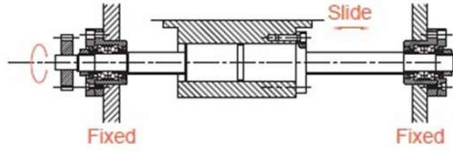

Fig 1.4.1

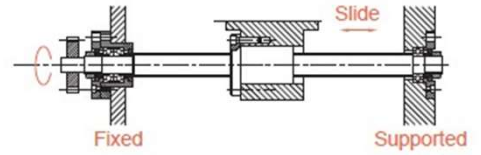

Fig 1.4.5

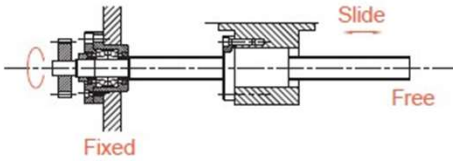

Fig 1.4.2

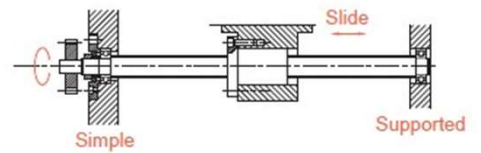

Fig 1.4.6

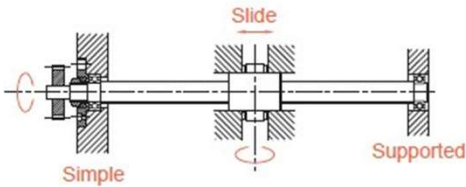

Fig 1.4.3

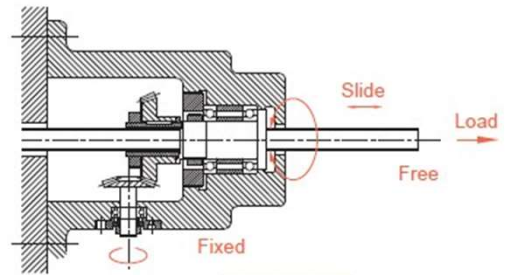

Fig 1.4.7

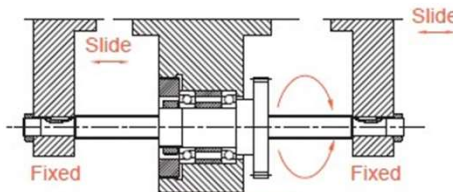

Fig 1.4.4

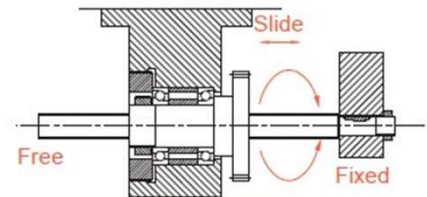
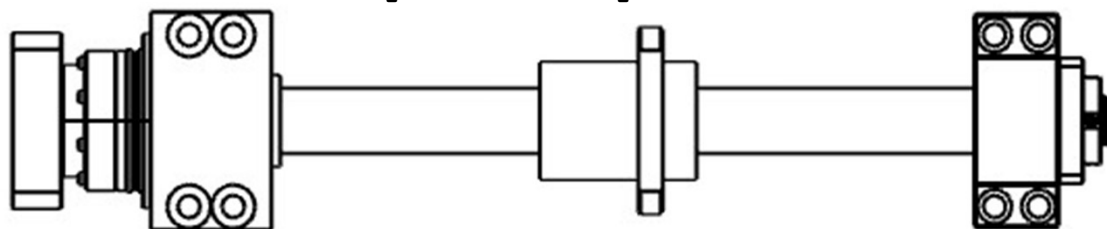

Fig 1.4.8



## Zero Tooth – Free/Fixed Zero Problem Motor Mounting

See ZeroTOOTH Catalog – Perfect Motor Alignment



# Pillow Block Fixed-Free End Supports

**BK FIX**  
**Fixed End Supports**

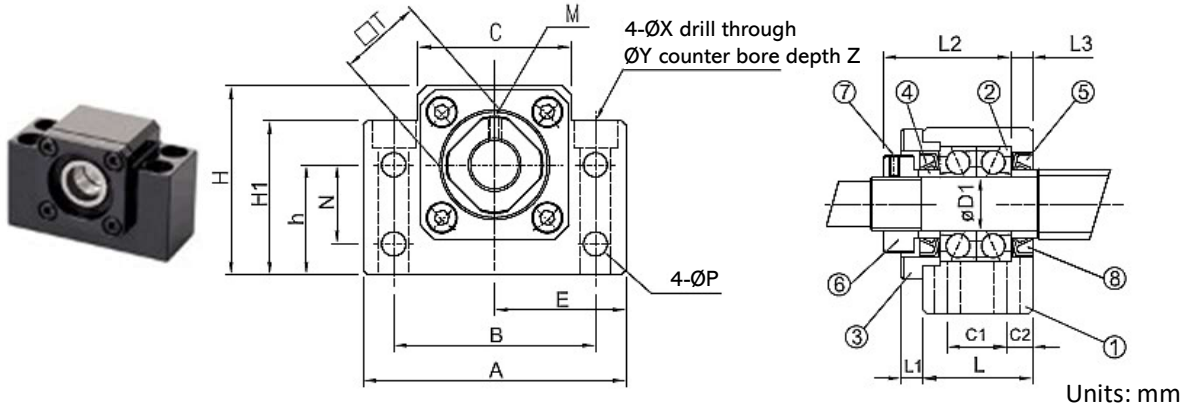

(D1 DIM) Ball Screw

Basic Model	(Dia)	(A)	(B)	(C)	(C1)	(C2)	(E)	(H)	(H1)	(h)	(L)	(L1)	(L2)	(L3)	(T)	(P)	(N)	(M)	(X)	(Y)	(Z)
BK12FIX	16	60	46	34	13	6	30	43	32.5	25	25	5	29	5	19	5.5	18	M3	6.6	11	1.5
BK15FIX	20	70	54	40	15	6	35	48	38	28	27	6	32	6	22	5.5	18	M3	6.6	11	6.5
BK20FIX	25	88	70	52	19	8	44	60	50	34	35	8	43	8	30	6.6	22	M4	9	14	8.5
BK25FIX	32	106	85	64	22	10	53	80	70	48	42	12	54	9	35	9	33	M5	11	17.5	11
BK30FIX	40	128	102	76	23	11	64	89	78	51	45	14	61	9	40	11	33	M6	14	20	13
BK40FIX	50	160	130	100	33	14	80	110	90	60	61	18	76	15	50	14	37	M8	18	26	17.5

**BF FREE**  
**Float End Supports**

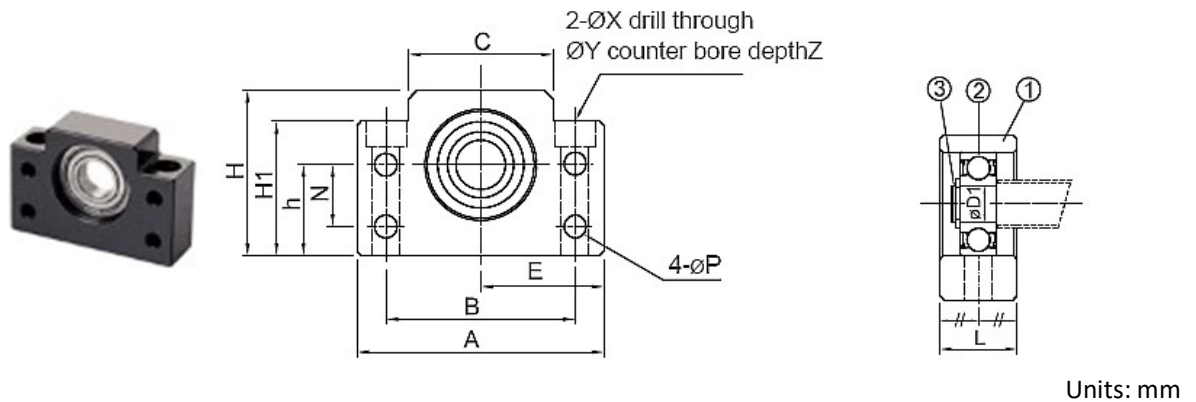

Ball Screw

Basic Model	(Dia)	(D1)	(A)	(B)	(C)	(E)	(H1)	(h)	(H)	(L)	(N)	(P)	(X)	(Y)	(Z)	(c-ring)
BF12FREE	16	10	60	46	35	30	32.5	25	43	20	18	5.5	6.6	11	1.5	C10
BF15FREE	20	15	70	54	40	35	38	28	48	20	18	5.5	6.6	11	6.5	C15
BF20FREE	25	20	88	70	52	44	50	34	60	26	22	6.6	9	14	8.5	C20
BF25FREE	32	25	106	85	64	53	70	48	80	30	33	9	11	17.5	11	C25
BF30FREE	40	30	128	102	76	64	78	51	89	32	33	11	14	20	13	C30
BF40FREE	50	40	160	130	100	80	90	60	110	37	37	14	18	26	17.5	C40

# Flanged Fixed-Free End Supports

**FK FIX**  
**Fixed End Supports**

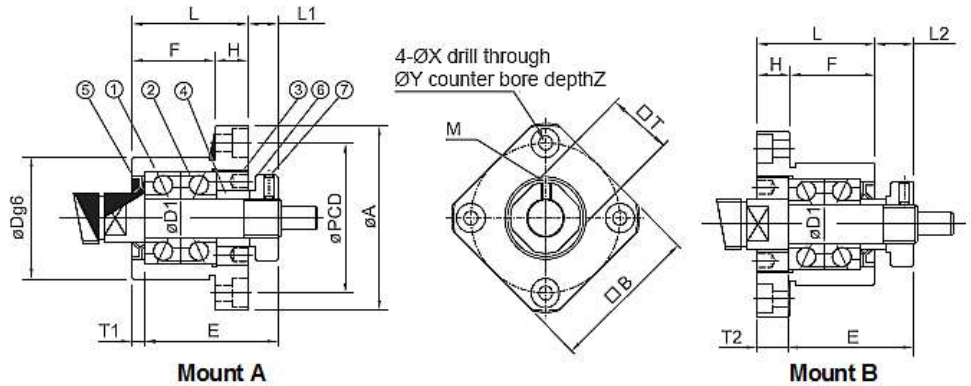

Units: mm

<u>(D1 DIM)</u>	<u>Ball Screw</u>	<u>(A)</u>	<u>(F)</u>	<u>(L)</u>	<u>(E)</u>	<u>(Dg6)</u>	<u>(H)</u>	<u>(PCD)</u>	<u>(M)</u>	<u>(B)</u>	<u>(L1)</u>	<u>(T1)</u>	<u>(L2)</u>	<u>(T2)</u>	<u>(X)</u>	<u>(Y)</u>	<u>(Z)</u>	<u>(T)</u>
<u>Basic Model</u>	<u>(Dia)</u>																	
FK10FIX	12/14/15	52	17	27	29.5	634	10	42	M3	42	7.5	5	8.5	6	4.5	8	4	16
FK12FIX	14/15/16	54	17	27	29.5	36	10	44	M3	44	7.5	5	8.5	6	4.5	8	4	19
FK15FIX	20/25	63	17	32	36	40	15	50	M3	52	10	6	12	8	5.5	9.5	6	22
FK20FIX	25	85	30	52	50	57	22	70	M4	68	8	10	12	14	6.6	11	10	10
FK25FIX	32	96	30	57	60	63	27	80	M5	79	13	10	20	17	9	15	13	35
FK30FIX	40	117	32	62	61	75	30	95	M6	93	14	12	17	18	11	18	15	40

**FF FREE**  
**Float End Supports**

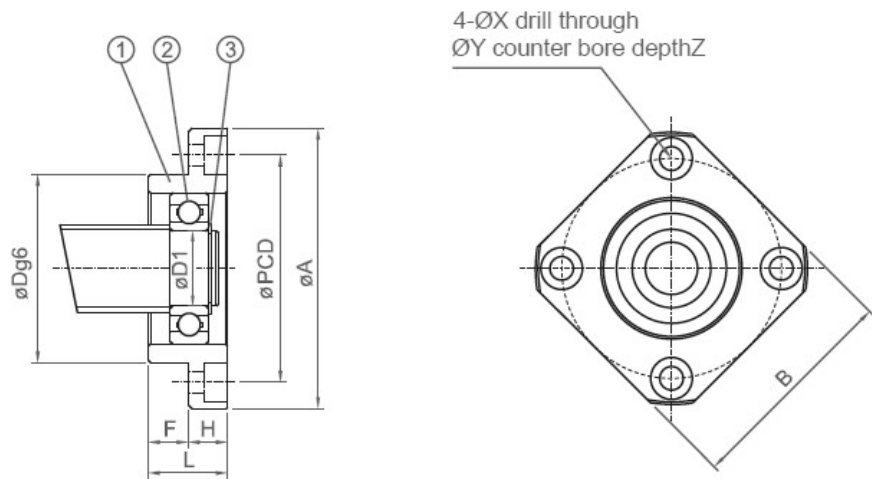

Units: mm

<u>Basic Model</u>	<u>Ball Screw</u>	<u>(D1)</u>	<u>(L)</u>	<u>(H)</u>	<u>(F)</u>	<u>(Dg6)</u>	<u>(A)</u>	<u>(PCD)</u>	<u>(B)</u>	<u>(X)</u>	<u>(Y)</u>	<u>(Z)</u>	<u>(c-ring)</u>
FF10FREE	12/14/15	8	12	7	5	28	43	35	35	3.4	6.5	64	C8
FF12FREE	14/15/16	10	15	7	8	34	52	42	42	4.5	8	4	C10
FF15FREE	20/25	15	17	9	8	40	63	50	52	5.5	9.5	5.5	C15
FF20FREE	25	20	20	11	9	57	85	70	68	6.6	11	6.5	C20
FF25FREE	32	25	24	14	10	63	98	80	79	8.5	14	8.5	C25
FF30FREE	40	30	27	18	9	75	75	95	93	11	17.5	11	C30





fang

**02TH**

**Screw Axis**

25X25, 32X32, 40X40

Perfect Motor Mount  
Ball Screws Assemblies

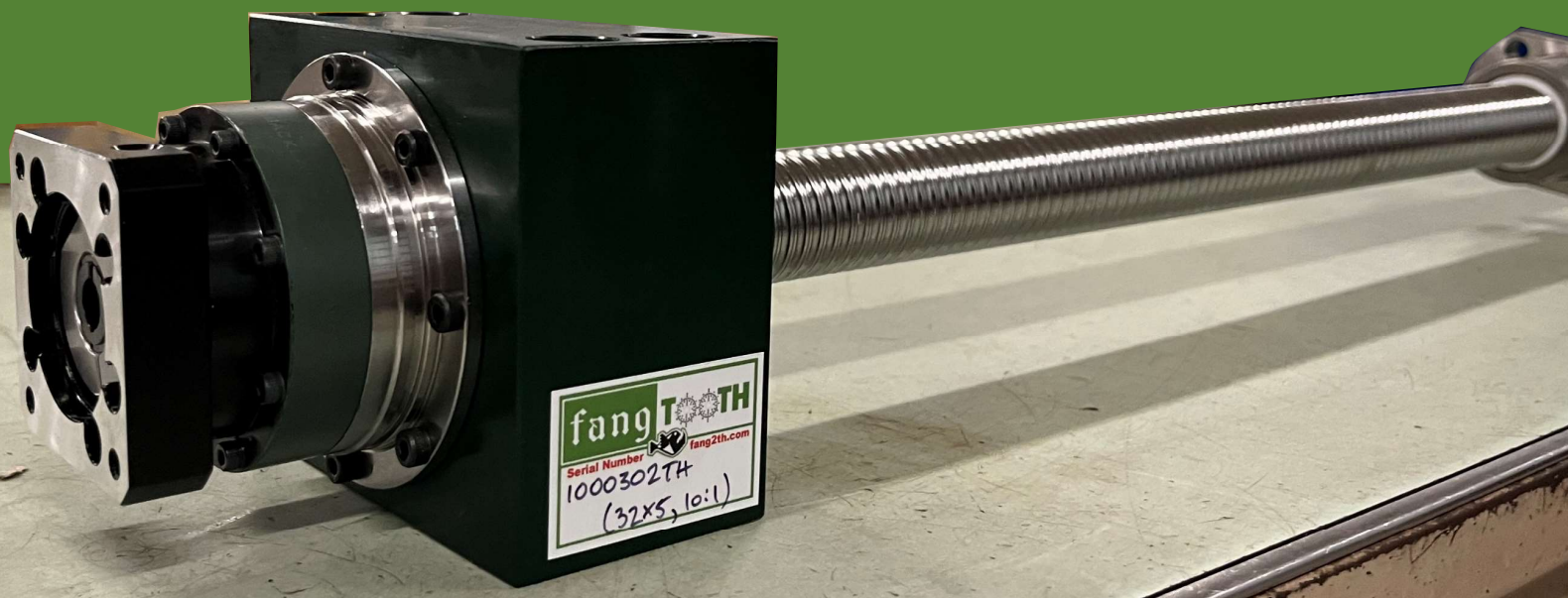

**FIXED/FLOAT  
BALL SCREW  
ASSEMBLIES**

**Simple to Drop into Design  
Longer Screws at Higher Speeds  
Increased Ball Screw L10 Life  
Perfect Motor Mount**

**Slip means Float for Float Adapter**

[www.fang2th.com](http://www.fang2th.com)



## Ball Screw Assemblies

Section	Page
Critical Notes .....	this page
Features.....	16
Recommended Lead Constants..	17
Ball Nut Ratings.....	17
Ordering.....	18
Dimensions zeroTOOTH.....	19
Gearbox Technical Data.....	20-22
Motion Profiles for Design .....	23
Horizontal Input Torque Charts..	24
Vertical Input Torque Charts.....	25

**NOTE 1: (S.L.I.P) Simple to Drop Into Your Design**

Engineers spend hours trying to get ball screw assemblies correct. By the time a design engineer has to create their own ball screw assembly, they need to (1) correctly specify the direction of the nut, (2) select the correct end bearings, (3) select the correct ball screw end machining & (4) figure out how to build a motor mount and (5) add a coupling. For many engineers, this can take days and there still are errors made. The Fangtooth Perfect Ball Screw Assembly is all in one.

**NOTE 2: (S.L.I.P) Longer Ball Screws at Higher Speeds.** Critical whip is always a ball screw issue. The longer the screw, the slower you need to spin it. But the standard aggressive leads on the Fangtooth ZeroTOOTH (02TH) allows high linear speeds. A 10mm lead needs to spin 4 times faster than a 40mm lead. The trick is the precision gearing in the ZeroTOOTH perfect motor mount.

**NOTE 3: (S.L.I.P) Increased Ball Screw L10 Life**

Slowing down the speed of the screw can quadruple its bearing life. For example, a 40X10 (40mm Diameter & 10mm lead) screw must spin at 3000 rpm to move at 500 mm/s. But using a 40X40 screw, it must only spin at 750 rpm. Adding a 10:1 gearbox adjusts the 40X40, in effect to a 40X10. Every revolution of the ball screw the bearings move in and out of the load zone much slower, which significantly reduces the bearing metal fatigue, thus extending the life of the ball nut.

**NOTE 4: (S.L.I.P) Perfect Motor Mount on the Fangtooth Ball Screw Assembly.**

Often ball screw integrations fail the motor coupling due to ball screw misalignment, but also the fixed thrust bearing is in the way of the motor mount. This assembly uses a clever float input and gearbox combination to solve both issues. The gearbox pilots on center for perfect alignment, acts as the float bearing and eliminates a coupling.



# zero**TOOTH** perfect motor mount FEATURES

## Ball Screw Assemblies

4

02THS2525  
02THS3232  
02THS4040

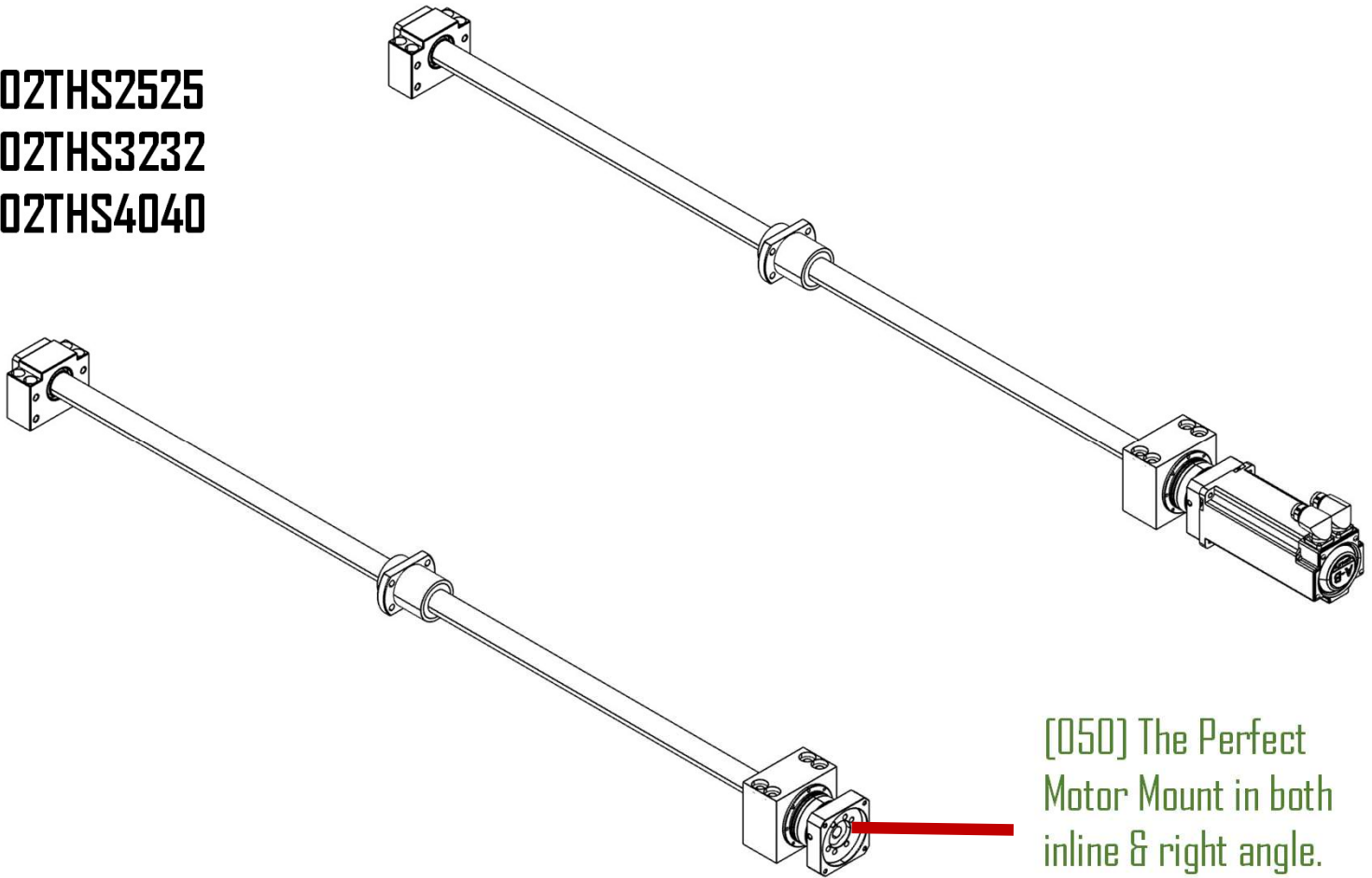

[050] The Perfect  
Motor Mount in both  
inline & right angle.

**Internally circulating balls**  
**Fixed / Float end bearings**  
**No Couplings!**

[100] Pre-Engineered fixed float end bearing assembly. Rolled or Ground ball screws. Ask about Planetary Roller Screws.

### CAPABILITIES

**Up to 1.3 m/s**

**Rolled Screws at  
C7 tolerances**

**Ground Screws to  
P3 tolerances**



## Recommended Lead Constants

### 25x25

- 10:1 Motor Mount - 2.5 mm / rev
- 7:1 Motor Mount - 3.571 mm / rev
- 5:1 Motor Mount - 5.0 mm / rev
- 4:1 Motor Mount - 6.25 mm / rev

### 32x32

- 10:1 Motor Mount - 3.2 mm / rev
- 7:1 Motor Mount - 4.571 mm / rev
- 5:1 Motor Mount - 6.4 mm / rev
- 4:1 Motor Mount - 8.0 mm / rev

### 40x40

- 10:1 Motor Mount - 4.0 mm / rev
- 7:1 Motor Mount - 5.714 mm / rev
- 5:1 Motor Mount - 8.0 mm / rev
- 4:1 Motor Mount - 10.0 mm / rev

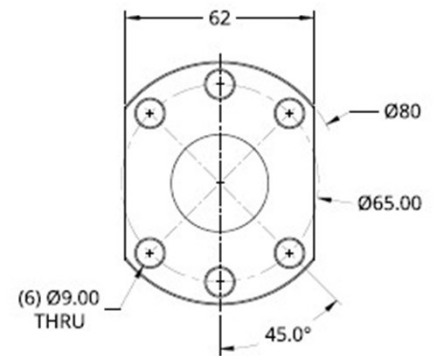
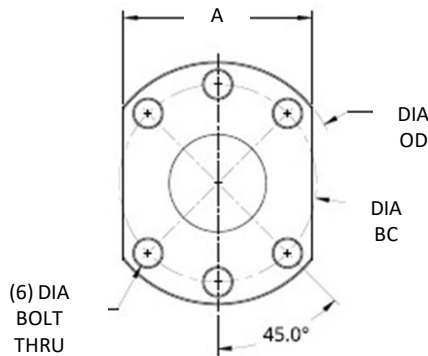

### Rolled

	<u>25 X 25</u>	<u>32 X 32</u>	<u>40 X 40</u>
Dynamic Capacity	12082 N (2716 lb)	18024 N (4052 lb)	37069 N (8333 lb)
Static Capacity	33548 N (7542 lb)	5329 kgf (11748 lb)	102293 N (23000 lb)
Backlash	0.000/0.005	0.000/0.005	0.000/0.005
Grade	C7	C7	C7
DIM A	48.0mm	62.0mm	70.0mm
DIM OD	62.0mm	80.0mm	93.0mm
DIM BC	51.0mm	65.0mm	78.0mm
DIM BOLT	6.6m	9.0mm	9.0mm
NUT LENGTH	89.0mm	112.0mm	138.0mm
NUT PILOT DIA	40.0mm	50.0mm	63.0mm

### Ground

	<u>25 X 25</u>	<u>32 X 32</u>	<u>40 X 40</u>
Dynamic Capacity	46000 N (10341 lb)	52500 N (11800 lb)	84500 N (19000 lb)
Static Capacity	35000 N (7870 lb)	45500 N (10230 lb)	76440 N (17850 lb)
Backlash	0.000/0.005	0.000/0.005	0.000/0.005
Grade	P5	P5	P5
DIM A	48.0mm	62.0mm	70.0mm
DIM OD	62.0mm	80.0mm	93.0mm
DIM BC	51.0mm	65.0mm	78.0mm
DIM BOLT	6.6m	9.0mm	9.0mm
NUT LENGTH	89.0mm	112.0mm	138.0mm
NUT PILOT DIA	40.0mm	50.0mm	63.0mm

# HOW TO ORDER zeroTOOTH STANDARD AXIS

## 02THS2525 and 02THS3232 and 02THS4040

### SCREW

Distance Between End Bearings (mm)

zeroTOOTH: 02THSC73232FX-06PL010-1000/MS2N04

C7 – Rolled Screw Tolerance  
P5 – Ground Screw Tolerance

**BALL SCREW DIAMETER**  
25 mm  
32 mm  
40 mm

**BALL SCREW LEAD**  
25 mm  
32 mm  
40 mm

Servo Motor PN

Gearbox:	Ratio:	
06PL – Size 6 Inline Planetary	004 – 4:1	030 – 30:1
06PR – Size 6 Right Angle Planetary	005 – 5:1	031 – 31:1
	007 – 7:1	035 – 35:1
	009 – 9:1	040 – 40:1
09PL – Size 9 Inline Planetary	010 – 10:1	050 – 50:1
09PR – Size 9 Right Angle Planetary	012 – 12:1	060 – 60:1
	014 – 14:1	061 – 61:1
	016 – 16:1	070 – 70:1
	020 – 20:1	080 – 80:1
	021 – 21:1	090 – 90:1
	025 – 25:1	091 – 91:1

FX – NUT FLANGE TOWARD MOTOR

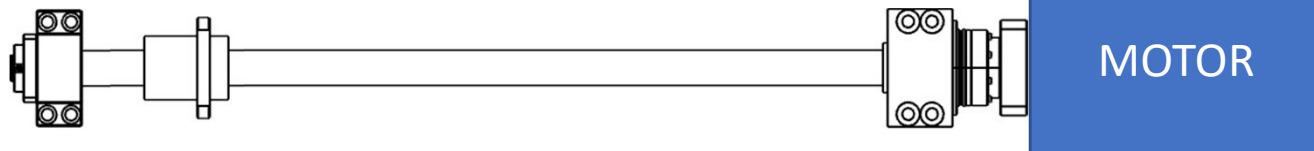

XF – NUT FLANGE OPPOSITE MOTOR

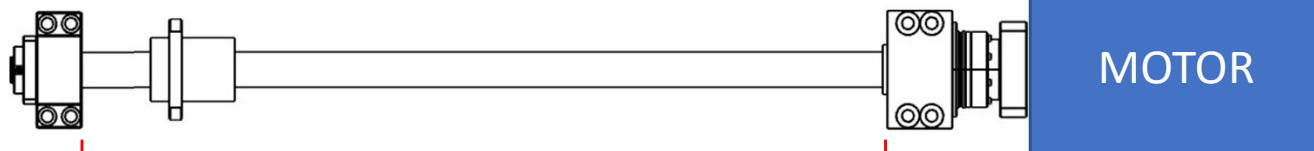

25X25: TRAVEL + 179 mm Rolled  
32X32: TRAVEL + 216 mm Rolled  
40X40: TRAVEL + 258 mm Rolled

### BETWEEN BEARING LENGTHS / TRAVEL

EXAMPLES	25X25	25X25	32X32	32X32	40X40	40X40
	BBL	Travel	BBL	Travel	BBL	Travel
	679	500	716	500	758	500
	979	800	1016	800	1058	800
	1179	1000	1216	1000	1258	1000
	1679	1500	1716	1500	1758	1500
	2379	2200	2416	2200	2458	2200
	2779	2600	2816	2600	2858	2600
	3179	3000	3216	3000	3258	3000
	3679	3500	3716	3500	3758	3500

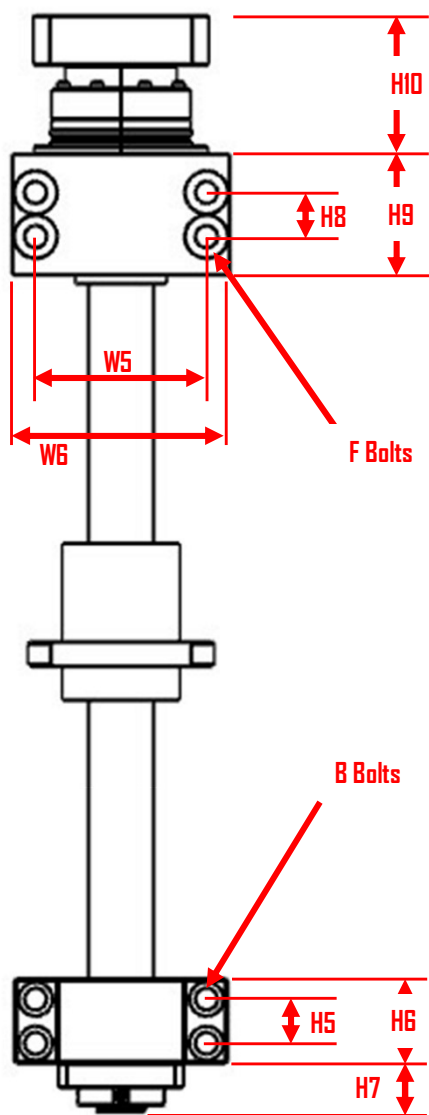

	25 X 25	32 X 32	40 X 40
DIM H3	48.0mm	48.0mm	60.0mm
DIM H4	72.0mm	80.0mm	89.0mm
DIM H5	19.0mm	22.0mm	23.0mm
DIM H6	35.0mm	42.0mm	45.0mm
DIM H7	15.0mm	20.0mm	25.0mm
DIM H8	22.0mm	22.0mm	26.0mm
DIM H9	60.0mm	60.0mm	60.0mm
DIM H10	63.0mm	63.0mm	69.5mm
DIM W3	85.0mm	85.0mm	114.0mm
DIM W4	88.0mm	106.0mm	128.0mm
DIM W5	85.0mm	85.0mm	114.0mm
DIM W6	108.0mm	108.0mm	130.0mm
DIM T1	22.0mm	33.0mm	33.0mm
DIM T2	24.0mm	15.0mm	18.0mm
F BOLTS	M10	M10	M12
B BOLTS	M8	M10	M12
HOLES	6.6	9	11

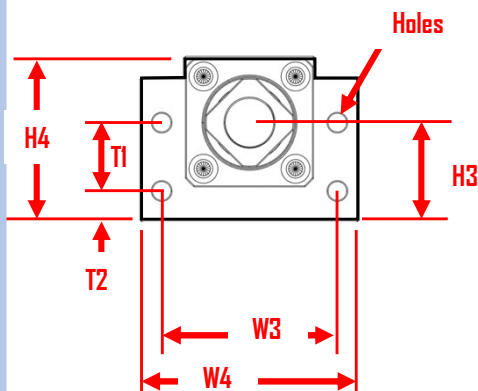

# GEARBOX TECHNICAL DATA

\* FANG2504 Max Input Torque = XX Nm (XX lb-in)

\* FANG2508 Max Input Torque = XX Nm (XX lb-in)

\* 06PL Planetary Values Based on 5000 rpm input

\* 09PL Planetary Values Based on 4000 rpm input



Type	RATIO	Inline / Right		Inline / Right	
		06PL	06PR	09PL	09PR
<b>Series</b>					
Nom Output Torque (T2n)	4:1	48 (425)	48 (425)	130 (1150)	130 (1150)
	5:1	60 (531)	60 (531)	160 (1416)	160 (1416)
	7:1	50 (442)	50 (442)	140 (1239)	140 (1239)
	10:1	40 (354)	60 (531)	100 (885)	160 (1416)
	14:1	NA	42 (372)	NA	140 (1239)
	16:1	48 (425)	NA	130 (1150)	NA
	20:1	48 (425)	40 (354)	130 (1150)	140 (1239)
	21:1	60 (531)	NA	160 (1416)	NA
	25:1	60 (531)	60 (531)	160 (1416)	160 (1416)
	31:1	50 (442)	NA	140 (1239)	NA
	35:1	50 (442)	50 (442)	140 (1239)	140 (1239)
	40:1	48 (425)	48 (425)	130 (1150)	130 (1150)
	50:1	60 (531)	60 (531)	160 (1416)	160 (1416)
	61:1	50 (442)	NA	140 (1239)	NA
	70:1	50 (442)	50 (442)	140 (1239)	140 (1239)
	91:1	40 (354)	NA	100 (885)	NA
	100:1	40 (354)	40 (354)	100 (885)	100 (885)
	140:1	NA	NA	NA	140 (1239)
	200:1	NA	NA	NA	10 (885)
	Nm (lb-in)				
4:1		72 (638)	72 (638)	195 (1725)	195 (1725)
5:1		90 (796)	90 (796)	240 (2124)	240 (2124)
7:1		75 (663)	75 (663)	210 (1859)	210 (1859)
10:1		60 (531)	90 (796)	150 (1327)	240 (2124)
14:1		NA	63 (558)	NA	210 (1859)
16:1		72 (638)	NA	195 (1725)	NA
20:1		72 (638)	90 (796)	195 (1725)	210 (1859)
21:1		90 (796)	NA	240 (2124)	NA
25:1		90 (796)	90 (796)	240 (2124)	240 (2124)
31:1		75 (663)	NA	210 (1859)	NA
35:1		75 (663)	75 (663)	210 (1859)	210 (1859)
40:1		72 (638)	72 (638)	195 (1725)	195 (1725)
50:1		90 (796)	90 (796)	240 (2124)	240 (2124)
61:1		75 (663)	NA	210 (1859)	NA
70:1		75 (663)	75 (663)	210 (1859)	210 (1859)
91:1		60 (531)	NA	150 (1327)	NA
100:1		60 (531)	60 (531)	150 (1327)	150 (1327)
140:1		NA	NA	NA	210 (1859)
200:1		NA	NA	NA	150 (1327)
Max Output Torque (T2n)					
	4:1	72 (638)	72 (638)	195 (1725)	195 (1725)
	5:1	90 (796)	90 (796)	240 (2124)	240 (2124)
	7:1	75 (663)	75 (663)	210 (1859)	210 (1859)
	10:1	60 (531)	90 (796)	150 (1327)	240 (2124)
	14:1	NA	63 (558)	NA	210 (1859)
	16:1	72 (638)	NA	195 (1725)	NA
	20:1	72 (638)	90 (796)	195 (1725)	210 (1859)
	21:1	90 (796)	NA	240 (2124)	NA
	25:1	90 (796)	90 (796)	240 (2124)	240 (2124)
	31:1	75 (663)	NA	210 (1859)	NA
	35:1	75 (663)	75 (663)	210 (1859)	210 (1859)
	40:1	72 (638)	72 (638)	195 (1725)	195 (1725)
	50:1	90 (796)	90 (796)	240 (2124)	240 (2124)
	61:1	75 (663)	NA	210 (1859)	NA
	70:1	75 (663)	75 (663)	210 (1859)	210 (1859)
	91:1	60 (531)	NA	150 (1327)	NA
	100:1	60 (531)	60 (531)	150 (1327)	150 (1327)
	140:1	NA	NA	NA	210 (1859)
	200:1	NA	NA	NA	150 (1327)



Type Series	RATIO	Inline / Right		Inline / Right	
		06PL	06PR	09PL	09PR
Efficiency %	4:1	97	95	97	95
	5:1	97	95	97	95
	7:1	97	95	97	95
	10:1	97	95	97	95
	14:1	NA	95	NA	95
	16:1	97	NA	97	NA
	20:1	97	95	97	95
	21:1	94	92	94	NA
	25:1	94	NA	94	92
	31:1	94	92	94	NA
	35:1	94	92	94	92
	40:1	94	92	94	92
	50:1	94	NA	94	92
	61:1	94	92	94	NA
	70:1	94	NA	94	92
	91:1	94	92	94	NA
	100:1	94	NA	NA	92
140:1	NA	NA	NA	92	
200:1	NA	NA	NA	92	
Mass Moment of Inertia(In)  Kg cm <sup>2</sup>	4:1	0.14	0.35	0.51	2.25
	5:1	0.13	0.35	0.47	2.25
	7:1	0.13	0.35	0.45	2.25
	10:1	0.13	0.35	0.44	2.25
	14:1	NA	0.31	NA	1.87
	16:1	0.03	NA	0.13	NA
	20:1	0.03	0.31	0.13	1.87
	21:1	0.03	NA	0.13	NA
	25:1	0.03	0.09	0.13	0.35
	31:1	0.03	NA	0.13	NA
	35:1	0.03	0.09	0.13	0.35
	40:1	0.03	0.09	0.13	0.35
	50:1	0.03	0.09	0.13	0.35
	61:1	0.03	NA	0.13	NA
	70:1	0.03	0.09	0.13	0.35
	91:1	0.03	NA	0.13	NA
	100:1	0.03	0.09	0.13	0.35
140:1	NA	NA	NA	0.31	
200:1	NA	NA	NA	0.31	



Type Series		Inline / Right		Inline / Right	
		06PL	06PR	09PL	09PR
Nom Input Speed (n1n)		5000	5000	4000	4000
Max Input Speed (1max)		10000	10000	8000	8000
1 STAGE arc-min		<5	<6	<5	<6
2 STAGE arc-min		<7	<9	<7	<9
Weight (m)	kg (lb) 1 STAGE	1.2 (2.65)	2.1 (4.63)	3.0 (6.61)	5.9 (13)
	kg (lb) 2 STAGE	1.6 (3.53)	1.9 (4.19)	3.7 (8.16)	4.5 (9.9)
Average Service Life		> 25,000 hours			
Lubrication		Sealed Synthetic Grease			
Protection Rating		IP67			
Operating Temperature		-10 to 90 C			

# FANGTOOTH REFERENCE MOTION PROFILES

## TO USED WITH FANG02th BALL SCREW SELECTION TABLES

### 500 mm MOVES

#### SECTION A - 25X25 [500mm of Travel – 16.68 inches]

<u>Profile #</u>	<u>Total Time</u>	<u>Accel Time</u>	<u>Decel Time</u>	<u>Speed</u>	<u>Acceleration</u>	<u>Motor Speed</u>	<u>Max Gearbox Ratio</u>
100.1a	4.00 sec	0.20 sec	0.20 sec	0.125 m/s	0.625 m/s <sup>2</sup>	3000.00 rpm	10:1
100.3a	2.20 sec	0.10 sec	0.10 sec	0.250 m/s	2.5 m/s <sup>2</sup>	2400.00 rpm	4:1
100.5a	1.20 sec	0.20 sec	0.20 sec	0.500 m/s	2.5 m/s <sup>2</sup>	4800.00 rpm	4:1

### 500 mm MOVES

#### SECTION B - 32X32 [500mm of Travel – 16.68 inches]

<u>Profile #</u>	<u>Total Time</u>	<u>Accel Time</u>	<u>Decel Time</u>	<u>Speed</u>	<u>Acceleration</u>	<u>Motor Speed</u>	<u>Max Gearbox Ratio</u>
100.1a	4.00 sec	0.20 sec	0.20 sec	0.125 m/s	0.625 m/s <sup>2</sup>	2350.00 rpm	10:1
100.3b	2.20 sec	0.10 sec	0.10 sec	0.250 m/s	2.5 m/s <sup>2</sup>	3280.00 rpm	7:1
100.5b	1.20 sec	0.20 sec	0.20 sec	0.500 m/s	2.5 m/s <sup>2</sup>	4688.00 rpm	5:1

### 500 mm MOVES

#### SECTION C - 40X40 [500mm of Travel – 16.68 inches]

<u>Profile #</u>	<u>Total Time</u>	<u>Accel Time</u>	<u>Decel Time</u>	<u>Speed</u>	<u>Acceleration</u>	<u>Size 2508 Max Motor Speed</u>	<u>Gearbox Ratio</u>
100.1a	4.00 sec	0.20 sec	0.20 sec	0.125 m/s	0.625 m/s <sup>2</sup>	1875.00 rpm	10:1
100.3c	2.20 sec	0.10 sec	0.10 sec	0.250 m/s	2.5 m/s <sup>2</sup>	1875.00 rpm	5:1
100.5c	1.20 sec	0.20 sec	0.20 sec	0.500 m/s	2.5 m/s <sup>2</sup>	3750.00 rpm	5:1
100.5d	1.20 sec	0.20 sec	0.20 sec	0.500 m/s	2.5 m/s <sup>2</sup>	5250.00 rpm	7:1

#### SIZING/SELECTION PRECAUTIONS:

Fangtooth Inc. is not responsible for and does not warrant (a) equipment, components and/or material furnished by the Buyer; (b) the sufficiency of functionality of any design specifications furnished by the Buyer; nor shall Company be liable for defects or damages arising from the foregoing. Notwithstanding any other provision in Fangtooth inc. Terms and Conditions, none of the warranties given by the Company shall apply to products manufactured by others and sold by the Company. Buyer will at its own expense arrange for any dismantling and reassembly of any goods and equipment and the provision of all equipment (including without limitation lifting equipment and crane-age) to the extent that this is necessary to remedy the defect or facilitate re-performance of service.

Fangtooth Inc. shall not be responsible for any claims which the Company determines are due to improper installation, operation above rated capacity, exceeds L10 life cycles, operation at extreme conditions, normal wear and tear, accident, or because the Product has been used, adjusted, altered, handled, maintained, repaired or stored other than as directed by the Company.

Tables published herein are intended as an estimated guide to help begin the design process. All applications require full evaluation against the actual intended use. Buyers select products at their own risk. Consider factors such as cycle duty and motor sizing due to torque, speed and heat requirements.



Warning: As this is only a general guide, to ensure acceptable system life please call Fangtooth Application Engineering with full duty cycle to verify.

Based on weight & Motion Profile from page

# MAXIMUM INPUT TORQUE REQUIREMENTS

12

## FANG02th BALL SCREW AXIS HORIZONTAL MOVES

### SECTION 25 [500mm of Travel – 16.68 inches] HORIZONTAL **25X25 mm**

Total Time	Speed	Profile #	75 lbs	150 lbs	300 lbs	600 lbs	1200 lbs	2400 lbs
4.00 sec	0.125 m/s	100.1a	0.03 Nm	0.07 Nm	0.12 Nm	0.22 Nm	0.41 Nm	0.79 Nm
2.20 sec	0.250 m/s	100.3a	0.19 Nm	0.32 Nm	0.58 Nm	1.10 Nm	2.15 Nm	4.24 Nm
1.20 sec	0.500 m/s	100.5a	0.19 Nm	0.32 Nm	0.58 Nm	1.10 Nm	2.15 Nm	4.24 Nm

### SECTION 32 [500mm of Travel – 16.68 inches] HORIZONTAL **32X32 mm**

Total Time	Speed	Profile #	3600 lbs	4800 lbs	6000 lbs	7500 lbs	8400 lbs	9600 lbs
4.00 sec	0.125 m/s	100.1a	NA	1.99 Nm	2.48 Nm	2.98 Nm	3.47 Nm	3.96 Nm
2.20 sec	0.250 m/s	100.3b	4.64 Nm	6.17 Nm	NA	NA	NA	NA
1.20 sec	0.500 m/s	100.5b	5.07 Nm	NA	NA	NA	NA	NA

### SECTION 40 [500mm of Travel – 16.68 inches] HORIZONTAL **40X40 mm**

Total Time	Speed	Profile #	4000 lbs	6000 lbs	7500 lbs	10000 lbs	15000 lbs	18000 lbs
4.00 sec	0.125 m/s	100.1a	NA	NA	NA	5.18 Nm	7.75 Nm	9.29 Nm
2.20 sec	0.250 m/s	100.3c	NA	NA	NA	22.38 Nm	NA	NA
1.20 sec	0.500 m/s	100.5c	9.02 Nm	13.47 Nm	16.81 Nm	NA	NA	NA
1.20 sec	0.500 m/s	100.5d	NA	NA	NA	16.04 Nm	NA	NA

Motion Profile #	Maximum End Bearing Centers	Based on Profile Move & Speed	Maximum Speed at 3.75m End Brg Centers	Maximum Speed at 4m End Brg Centers	Maximum Speed at 4.5m End Brg Centers	Maximum Speed at 5m End Brg Centers
100.1a 100.3a 100.5a	3200 mm 2300 mm 1600 mm	<b>25X25 mm</b>	95 mm/s	80 mm/s	65 mm/s	50 mm/s
100.1a 100.3a 100.5a	4200 mm 2950 mm 2100 mm	<b>32X32 mm</b>	159 mm/s	140 mm/s	110 mm/s	85 mm/s
100.1a 100.3a 100.5a	5200 mm 3700 mm 2600 mm	<b>40X40 mm</b>	247 mm/s	210 mm/s	165 mm/s	135 mm/s





Warning: As this is only a general guide, to ensure acceptable system life please call Fangtooth Application Engineering with full duty cycle to verify.

Based on weight & Motion Profile from page

# MAXIMUM INPUT TORQUE REQUIREMENTS

13

## FANG02th BALL SCREW AXIS VERTICAL MOVES

### SECTION 25 [500mm of Travel – 16.68 inches] VERTICAL

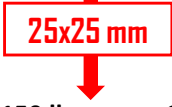

Total Time	Speed	Profile #	75 lbs	150 lbs	300 lbs	400 lbs	500 lbs	600 lbs
4.00 sec	0.125 m/s	100.1a	0.18 Nm	0.34 Nm	0.95 Nm	0.86 Nm	1.07 Nm	1.28 Nm
2.20 sec	0.250 m/s	100.3a	0.52 Nm	0.98 Nm	1.91 Nm	2.52 Nm	3.14 Nm	3.75 Nm
1.20 sec	0.500 m/s	100.5a	0.52 Nm	0.98 Nm	1.91 Nm	2.52 Nm	3.14 Nm	3.75 Nm

### SECTION 32 [500mm of Travel – 16.68 inches] VERTICAL

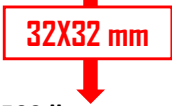

Total Time	Speed	Profile #	400 lbs	500 lbs	600 lbs	750 lbs	900 lbs	1250 lbs
4.00 sec	0.125 m/s	100.1a	1.09 Nm	1.35 Nm	1.62 Nm	2.02 Nm	2.42 Nm	2.42 Nm
2.20 sec	0.250 m/s	100.3b	1.86 Nm	2.31 Nm	2.76 Nm	3.43 Nm	-	-
1.20 sec	0.500 m/s	100.5b	2.03 Nm	2.52 Nm	3.02 Nm	-	-	-

### SECTION 40 [500mm of Travel – 16.68 inches] VERTICAL



Total Time	Speed	Profile #	1500 lbs	1750 lbs	2000 lbs	2250 lbs	2500 lbs	2750 lbs
4.00 sec	0.125 m/s	100.1a	5.05 Nm	5.89 Nm	6.73 Nm	7.56 Nm	8.39 Nm	9.23 Nm
2.20 sec	0.250 m/s	100.3c	11.92 Nm	13.89 Nm	-	-	-	-

Motion Profile #	Maximum End Bearing Centers	Based on Profile Move & Speed	Maximum Speed at 3.75m End Brg Centers	Maximum Speed at 4m End Brg Centers	Maximum Speed at 4.5m End Brg Centers	Maximum Speed at 5m End Brg Centers
100.1a 100.3a 100.5a	3200 mm 2300 mm 1600 mm	25X25 mm	95 mm/s	80 mm/s	65 mm/s	50 mm/s
100.1a 100.3a 100.5a	4200 mm 2950 mm 2100 mm	32X32 mm	159 mm/s	140 mm/s	110 mm/s	85 mm/s
100.1a 100.3a 100.5a	5200 mm 3700 mm 2600 mm	40X40 mm	247 mm/s	210 mm/s	165 mm/s	135 mm/s





## SECTION 1: APPLICABILITY

1.1 These terms & conditions (the "Terms and Conditions") of sale are applicable to all quotations for the sale or orders for the purchase of all equipment or goods (the "Products") made by or for Fangtooth Inc 11970 Mayfield St. Livonia MI 48150 ("Company".)

1.2 Unless otherwise agreed, written quotations are valid for 30 days from the date of quotation. All price lists and discounts are subject to change without notice.

1.3 All orders placed by the Buyer are subject to written acceptance by the Company. No contract between Buyer and Company shall exist prior to the time of such acceptance by the Company.

1.4 These Terms & Conditions supersede all prior written terms, understandings, purchase orders, assurances and offers. Company shall not be deemed to have waived these Terms & Conditions if it fails to object to the conditions appearing in or attached to a purchase order issued by Buyer. Buyer's acceptance of the Products or services furnished by the Company shall constitute its acceptance of these Terms & Conditions.

## SECTION 2: PRICE & SHIPPING DATES

2.1 All orders must be bona fide commitments showing a complete description of equipment, quantity, price & shipping dates required by the Buyer.

2.2 Timely performance by Company is contingent upon Buyer supplying to Company, when applicable, all required technical information and data, including drawing approvals, and all required commercial documentation. Shipping dates are subject to final confirmation or change by Company and are based on prompt receipt of all necessary information regarding the order. Unless otherwise indicated, all delivery dates specified by the Company are estimated time frames and time is not of the essence in Company's performance of the sale of the Products.

2.3 If shipment is delayed for thirty (30) days or more from the delivery date accepted by the Company for reasons attributable to the Buyer and provided that the Buyer shall have no other liability to the Company in respect of such delay, the reasonable direct costs of putting the Products into storage at a facility off-site of Company's premises until such times as they are shipped (or delivered) shall be the to the Buyer's account and at Buyer's sole risk.

## SECTION 3: PAYMENT

Terms of payment are net 30 days from the date of invoice unless otherwise agreed in writing. Late payments may be subject to interest on the unpaid balance at the greater of 2% per month or the maximum rate permitted by law. No deductions or set-offs are to be made by Buyer from amounts due unless specifically authorized by the Company in writing. If in the judgment of the Company, the financial condition of Buyer at any time does not justify continuance of production or shipment on the terms of payment specified, the Company may require full or partial payment in advance.

## SECTION 4: TAXES

The Company's prices do not include sales, use, excise taxes, tariffs, duties or value added or similar taxes or fees. The Company will add such taxes or fees to the invoice unless the Buyer provides Company with tax-exempt certificate acceptable to the applicable taxing authorities or arranges payment of such taxes or fees directly by the Buyer.

## SECTION 5: WARRANTY

5.1 NEW PRODUCT – Company warrants the Products shall be free of defects in material and workmanship and meet the Product specifications for a period from the date of shipment as specified below.

5.1.a FANGTOOTH MAX straddle mounted pinion systems – 3 years.

5.1.b FANGTOOTH OPEN cantilevered pinion systems – 2 years.

5.1.c FANGTOOTH Any products not specified as standard including any units with non-standard coatings for corrosion claims – 1 year.

5.1.d FANGBOT integrated systems – FANGTOOTH MAX integrated into larger systems will carry the full 3 year warranty. FANGTOOTH OPEN integrated into larger systems will carry the full 2 year warranty. Custom (non-standard) engineered products within the larger systems or any other non-standard FANGTOOTH products will be warranties for 18 months.

5.2 Notwithstanding the warranty periods listed above, the warranty on normal wear items such as oil seals is limited to one year. The warranties of gearboxes, motors, brakes, couplings, linear rail, linear bearings, gear rack and pinion and all other add on items shall be the warranties provided by, and shall be the responsibility of, the original equipment manufacturer. The Company is not responsible for and does not warrant (a) equipment, components and/or material furnished by the Buyer; (b) the sufficiency of functionality of any design specifications furnished by the Buyer; nor shall Company be liable for defects or damages arising from the foregoing. Notwithstanding any other provision in these Terms and Conditions, none of the warranties given by the Company shall apply to products manufactured by others and sold by the Company. Buyer will at its own expense arrange for any dismantling and reassembly of any goods and equipment and the provision of all equipment (including without limitation lifting equipment and crane-age) to the extent that this is necessary to remedy the defect or facilitate re-performance of service.

Unless otherwise agreed, necessary transport of the Products and/or parts thereof to and from Company in connection with the remedying of defects will be at the risk and expense of the Buyer. Buyer will follow Company's instructions regarding such transport.

Unless otherwise agreed, Buyer will bear any additional costs which Company incurs as a result of the Products being located in a place other than the place of delivery.

Defective parts which have been replaced will be made available to Company and will be its property.

5.3 Any claims under this warranty must be made in writing to the Company at the address set forth above (or by email) within thirty (30) days of the discovery thereof. The

Company's obligation under this warranty shall be limited to the repair or replacement, at the Company's option, of the Product, or any part thereof, when the Company has determined the Product is not warranted; any Product or parts repaired or replaced pursuant to the warranty will be warranted for the remainder of the original warranty period. The Company shall not be responsible for any claims which the Company determines are due to improper installation, operation above rated capacity, exceeds L10 life cycles, operation at extreme conditions, normal wear and tear, accident, or because the Product has been used, adjusted, altered, handled, maintained, repaired or stored other than as directed by the Company.

5.4 This warranty shall not apply in the event of defects caused by: (i) physical abuse of the Products or any component, or acts of vandalism by any persons other than Company; (ii) alterations, modifications, additions, or repairs made during the applicable warranty period by anyone other than Company, and its authorized employees, agents or subcontractors; (iii) accidents or damage resulting from fire, water, wind, hail, lightning, electrical surge or failure, earthquake, theft or similar causes not caused by the sole negligence of Company; (iv) damage as a result of corrosion or other damage caused by Buyer's failure to protect and maintain the Products in accordance with Company's written instructions and warnings; or (v) design specifications furnished by Buyer.

5.5 Buyer shall not rely upon Company's skill or judgement or furnish Products for any particular purpose beyond the specific express warranties provided herein. Buyer has the responsibility to determine whether the Products and specifications are fit for buyer's intended purpose. Company does not warrant the Products will comply with the requirements or any safety code or regulations, or with any environmental or other law or regulation. Buyer is responsible for the safe and lawful operation and use of the Products.

5.9 THE FOREGOING WARRANTIES ARE THE SOLE WARRANTIES PROVIDED BY COMPANY FOR THE PRODUCTS AND ARE IN LIEU OF ALL OTHER WARRANTIES, EXPRESS OR IMPLIED, ALL OF WHICH ARE HEREBY DISCLAIMED AND EXCLUDED BY MERCHANTABILITY OR FITNESS FOR A PARTICULAR PURPOSE OR USE. BUYER AGREES THAT ITS SOLE AND EXCLUSIVE REMEDY AGAINST COMPANY WILL BE LIMITED TO THE REPAIR AND REPLACEMENT OF NONCONFORMING OR DEFECTIVE PRODUCTS PROVIDED COMPANY IS PROMPTLY NOTIFIED IN WRITING OF ANY DEFECT. THIS EXCLUSIVE REMEDY WILL NOT BE DEEMED TO HAVE FAILED OF ITS ESSENTIAL PURPOSE SO LONG AS COMPANY IS WILLING TO REPAIR OR REPLACE THE NONCONFORMING OR DEFECTIVE PRODUCTS.

## SECTION 6: OWNERSHIP OF INTELLECTUAL PROPERTY

Company retains ownership and all rights to its intellectual property. Buyer shall have no rights to Company's intellectual property. Any intellectual property developed by Company and arising in connection with the supply of Products hereunder shall be deemed property of Company, and Company shall have exclusive rights to the use and ownership of such intellectual property.

## SECTION 7: THIRD PARTY INTELLECTUAL PROPERTY CLAIMS

Company shall pay costs and damages finally awarded in any suit against Buyer by a third party to the extent based upon a finding that the design or construction of the Products as furnished infringes a patent or other third party intellectual property rights (except infringement occurring as a result of incorporating a design or modification at Buyer's request), provided that Buyer promptly notifies Company of any charge of infringement, and Company is given the right at its expense to settle such charge and to defend or control the defense of any suit based upon such charge. Company shall have no obligation hereunder with respect to claims, suits or proceedings, resulting from or related to, in whole or in part, (i) the use of software or software documentation, (ii) compliance with Buyer's specifications, (iii) the combination with other products, or modification of, the Products after delivery by Company, or (iv) the use of the Products, or any part thereof, in the practice of a process. THIS SECTION SETS FORTH COMPANY'S ENTIRE LIABILITY WITH RESPECT TO PATENTS OR OTHER INFRINGEMENTS OF INTELLECTUAL PROPERTY.

## SECTION 8: RETURN OF PRODUCTS

In the event that the Buyer does not accept the Products, the Buyer must apply for authorization from the Company before returning the Products to the Company for credit. The Company will advise the Buyer of the credit to be allowed and necessary restocking charges on the unused material, subject to the Company's inspection and acceptance when received. No material should be returned to the Company except upon receipt of written authorization. In addition to the usual restocking charges, the Buyer must pay the actual transportation expense of the Company, plus all return transportation costs. Motors and specially designed parts will not be accepted for return or credit.

## SECTION 9: DELIVERY, TITLE AND RISK OF LOSS

The Products will be delivered Ex Works – Fangtooth Inc's facility (in accordance with Incoterms 2010) unless otherwise agreed in writing by Company. The Buyer will be responsible for making all shipping arrangements, and Buyer will provide sufficient notice and details of such arrangements to allow Company to prepare the Products for delivery. Title and risk of loss will remain with Company and not pass to Buyer until delivery to the Incoterm delivery point.

## SECTION 10: FORCE MAJEURE

Company will not be deemed to be in default or otherwise responsible for delays or failures in performance resulting from acts of God: acts of war, or civil disturbance, terrorism, epidemics, governmental action or inaction, fires, floods, earthquakes, tornadoes, or other events beyond Company's reasonable control (a "Force majeure Event"). A Force Majeure Event affecting Company's vendors shall also be deemed as a Force Majeure Event for the Company, provided that the Company shall use commercially reasonable efforts to mitigate any delays caused by its vendor's Force Majeure situation. Company shall in such instances give notice of the non-performance (including its anticipated duration) to the Customer promptly after becoming aware that it has occurred or will occur. In no event shall lack of finances or ability to pay as a result of the financial condition of either party be considered a Force Majeure Event.

**SECTION 11: CANCELLATION**

Upon written acceptance of an order by the Company, Buyer may not cancel or terminate for convenience, or direct suspension of manufacture, except with Company's written consent and then only upon terms that will compensate Company for its engineering, fabrication and purchasing charges and any other costs relating to such cancellation, termination, or suspension, plus a reasonable amount for profit and overhead.

**SECTION 12: ETHICAL BUSINESS PRACTICES**

Company requires manufacturing and business practices that are compliant with all applicable laws and regulations, including, the need to conduct all transactions in compliance with ethical business practices. Both the Company and the Buyer agree that neither of them nor their employees, agents, representatives, or other intermediaries will engage in any activity that may be construed to be in violation of their respective codes of ethical business practices or applicable law. Buyer acknowledges and agrees that it shall not, in regards to the sale or resale of the Company's products, make any payment or transfer of value to any third party (including through any or multiple intermediaries) that would cause either the Buyer, Company or any of Company's affiliates to violate either the U.S. Foreign Corrupt Practices Act or any other applicable anti-corruption laws. Buyer shall indemnify and hold Company and Company's affiliates harmless in the even of any breach of this paragraph by buyer or any of its intermediaries.

**SECTION 13: LIMITATION OF LIABILITY**

NEITHER COMPANY AND ITS AFFILIATES AND THEIR RESPECTIVE OFFICERS, DIRECTORS, EMPLOYEES, AGENTS, INSURERS AND ATTORNEYS SHALL BE LIABLE, WHETHER IN CONTRACT, WARRANTY, FAILURE OF A REMEDY TO ACHIEVE ITS INTENDED OR ESSENTIAL PURPOSES, TORT (INCLUDING LOSS OF USE, REVENUE OR PROFIT, OR FOR COSTS OF CAPITAL OR OF SUBSTITUTE USE OR PERFORMANCE, OR FOR INDIRECT, SPECIAL, LIQUIDATED, INCIDENTAL OR CONSEQUENTIAL DAMAGES, OR FOR ANY OTHER LOSS OR COST OF SIMILAR TYPE, OR FOR OTHER CLAIMS BY BUYER FOR ANY DAMAGES OR LOSSES. COMPANY'S MAXIMUM LIABILITY FOR ALL CLAIMS AND LOSSES ARISING OUT OF THE MANUFACTURE OR SALE OF THE PRODUCTS SHALL BE THE PRICE CONFIRMED BY THE COMPANY RELATING TO THE INDIVIDUAL SALE TRANSACTION WITH THE BUYER. BUYER AND COMPANY AGREE THAT THE EXCLUSIONS AND LIMITATIONS SET FORTH IN THIS SECTION ARE SEPARATE AND INDEPENDENT FROM ANY REMEDIES WHICH BUYER MAY HAVE HEREUNDER AND SHALL BE GIVEN FULL FORCE AND EFFECT WHETHER OR NOT ANY OR ALL SUCH REMEDIES SHALL BE DEEMED TO HAVE FAILED OF THEIR ESSENTIAL PURPOSE.

**SECTION 14: GOVERNING LAW**

The terms of the sales of the Products shall be governed and controlled in all respects by the laws of the State of Michigan and all disputes, including interpretation, enforceability, validity, and construction, shall be determined under the law of the State of Michigan without regard to any conflict of law provisions. Any dispute arising between the parties will be finally resolved in the state or federal courts of Michigan. Each party consents to personal jurisdiction in the state and federal courts of the State of Michigan for any all matters related to or arising out of the sale, attempted sale, delivery, warranty, maintenance or use of the Products, and agrees that personal jurisdiction in any such court will be deemed proper. Buyer shall be liable to Company for any attorney fees and costs incurred by Company in enforcing any of its rights hereunder.

**SECTION 15: STATUTE OF LIMITATIONS**

To the extent permitted by applicable law, any lawsuit for breach of contract, including breach of warranty, arising out of the transactions covered by this Purchase Order, must be commenced not later than twelve (12) months from the date the cause of action accrued.

**SECTION 16: CHANGES IN LAWS AND REGULATIONS**

Company's prices and timely performance are based on all applicable laws, rules, regulations, orders, codes, standards or requirements of governmental authorities effective on the date of Company's proposal. Any applicable change to the forgoing shall entitle Company to an equitable adjustment in the prices and time of performance.

**SECTION 17: COMPLIANCE WITH EXPORT LAWS AND REGULATIONS**

Certain Products manufactured by Company, as well as technical data related thereto, may be subject to export licensing controls under the U.S. Export Administration Regulations and/or the U.S. International Traffic in Arms Regulations, which require licensing for and/or prohibit the export or diversion of the Company's products to certain countries. If Buyer is responsible for obtaining export approvals. Buyer warrants that it will not assist or participate in any export of the Company's products or related technical data without first obtaining the required export license and will not knowingly assist or participate in any such diversion or other violation of applicable U.S. laws and regulations. If Company is responsible for obtaining export approvals, Buyer shall assist the Company, as necessary, in obtaining such approvals. Buyer shall indemnify and hold the Company and its affiliates harmless from any losses or claims arising out of or related to Buyer's failure to comply with applicable export control laws and regulations.

**SECTION 18: COMPLIANCE WITH LAWS**

Buyer agrees to comply with all applicable local, state, Federal and Foreign laws, orders, directives, and regulations at any time in effect, including, but not limited to, those found in 41 CFR 60 requiring equal opportunity and affirmative action without regard to race, color, religion, sex, national origin, presence of disability or status as a special disabled veteran or Vietnam era veteran, which specifically incorporated herein by reference. If Buyer fails to comply with the provisions of this paragraph, Company may, by written notice to Buyer, terminate any Order for Buyer's default in addition to exercising any other rights or remedies provided by law.

**SECTION 19: RELATIONSHIP OF THE PARTIES**

Buyer and Company are independent contractors, and nothing in the contract makes either party the agent or legal representative of the other party for any purpose. Neither party has authority to assume or to create any obligation on behalf of the other party.

**SECTION 20: WAIVER**

The failure of Company to enforce any right or remedy provided in contract or by law on a particular occasion will not be deemed a waiver of that right or remedy on a subsequent occasion or a waiver of any other right or remedy.

**SECTION 21: SEVERABILITY**

A finding that any provision in these Terms & Conditions or an accepted purchase order is invalid or unenforceable in any jurisdiction will not affect the validity or enforceability of any other provision of these Terms & Conditions or an accepted purchase order or the validity or enforceability of that provision in any other jurisdiction.

**SECTION 22: ASSIGNMENT and DELEGATION**

No right or interest in the sale of Products hereunder shall be assigned by the Buyer without written permission of the Company. No delegation of any obligation owed, or the performance of any obligation by the Buyer, shall be made without the written permission of the Company. Any attempted assignment of delegation shall be wholly void and totally ineffective for all purposes unless made in conformity with this section. Company shall have the right to assign its obligations to any affiliate of the Company or any successor to substantially all the business or assets of the Company.

**SECTION 23: THIRD PARTY RIGHTS**

Notwithstanding any provision of law, no third party (including Buyer's customer) shall have the right to enforce these Terms & Conditions or any other contractual rights against Company or its affiliates.

**SECTION 24: HEADINGS**

The headings of the various paragraphs of these Terms & Conditions have been inserted for convenient reference only and shall not to any extent have the effect of modifying, amending, or changing the expressed terms and provisions hereof.

**SECTION 25: ENTIRE AGREEMENT**

These Terms & Conditions, including any attachments hereto, constitutes the entire understanding and agreement between the parties and supersedes any prior oral or written agreements with respect to the subject matter hereof. No course of prior dealings between the and the Buyer, and no usage of the trade shall be relevant to supplement or explain and term used herein. Acceptance or acquiescence in a course of performance rendered hereunder shall not be relevant to determine the meaning of these Terms & Conditions even though the accepting or acquiescing party has knowledge of the performance and opportunity for objection. Whenever a term defined by the Uniform Commercial Code is used herein, the definition contained in the Uniform Commercial Code shall control



**Planetary Lift**

**Ball Screw Lift**



**NEPTUNE  
TRITON**

**Standard Rack Axis**

**Heavy Rack Axis**

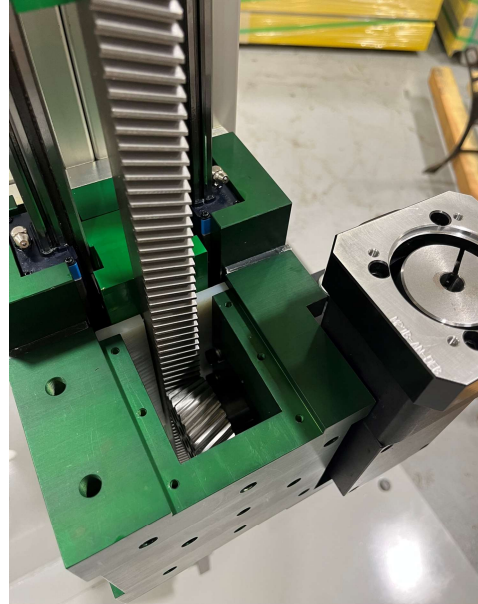

**fangOPEN  
fangMAX**



**Fangtooth Inc.**  
11790 Mayfield St  
Livonia, MI 48150  
Ph 248-798-4877



**ACTUATORS**



**GEAR  
BOXES**

**ROLLED  
BALLSCREWS**



**HIGH FORCE  
LIFTING JACKS  
& GUIDED RACK**



**MULTI  
AXIS  
SYSTEMS**



**CUSTOM  
ENGINEERED  
PRODUCTS**